



PhilGEPS

Philippine Government Electronic Procurement System

Central Portal for
Philippine Government
Procurement Opportunities

Bid Notice Abstract

Request for Quotation (RFQ)

Reference Number 10936592
Procuring Entity CARLOS HILADO MEMORIAL STATE UNIVERSITY
Title Procurement of Glass Division with Installation for the Cashier and Assessment Offices and a Separate Door for the Cashier's Office in Fortune Towne Campus
Area of Delivery Negros Occidental

Solicitation Number:	RFQ 24-264	Status	Pending
Trade Agreement:	Implementing Rules and Regulations	Associated Components	1
Procurement Mode:	Negotiated Procurement - Small Value Procurement (Sec. 53.9)	Bid Supplements	0
Classification:	Goods	Document Request List	0
Category:	Fixtures	Date Published	08/06/2024
Approved Budget for the Contract:	PHP 100,000.00	Last Updated / Time	07/06/2024 16:55 PM
Delivery Period:	20 Day/s	Closing Date / Time	14/06/2024 09:00 AM
Client Agency:			
Contact Person:	Rowena De la Vida Prado Administrative Assistant II Mabini Street Talisay City Negros Occidental Philippines 6115 63-34-7120005 Ext.142 63-939-9296624 bac.sec@chmsu.edu.ph		

Description

Republic of the Philippines
 CARLOS HILADO MEMORIAL STATE UNIVERSITY
 Talisay City, Negros Occidental
 Mobile Phone Number: 0939 929 6624
 bac.sec@chmsu.edu.ph

REQUEST FOR QUOTATION

Page 1 of 5
 Date: JUNE 06, 2024
 Quotation No. 24-264

Please quote your lowest price on the item/s listed below, stating the shortest time of delivery and submit your quotation duly signed by your representative not later than _____ in the return envelope attached herewith.

DR. ANDREW EUSEBIO S.TAN
 BAC Chairman

NOTE:

- ALL ENTRIES MUST BE TYPEWRITTEN
- DELIVERY PERIOD WITHIN 20 CALENDAR DAYS
- WARRANTY SHALL BE FOR A PERIOD OF SIX (6) MONTHS FOR SUPPLIES & MATERIALS, ONE (1) YEAR FOR EQUIPMENT, FROM DATE OF ACCEPTANCE BY THE PROCURING ENTITY

4. PRICE VALIDITY SHALL BE FOR A PERIOD OF _____ CALENDAR DAYS
 5. G-EPS REGISTRATION CERTIFICATE SHALL BE ATTACHED UPON SUBMISSION OF THE QUOTATION
 6. BIDDERS SHALL SUBMIT ORIGINAL BROCHURES SHOWING CERTIFICATIONS OF THE PRODUCT BEING OFFERED

ITEM DESCRIPTION OF WORKS QTY. UNIT MATERIAL COST LABOR COST TOTAL COST
 NO. Unit Cost Material Sub-Total Cost Unit Cost Labor Sub-Total Cost

ONE (1) LOT
 LABOR AND MATERIALS FOR THE INSTALLATION OF GLASS DIVISION FOR CASHIER AND ASSESSMENT OFFICES
 AND A SEPARATE DOOR FOR THE CASHIER'S OFFICE AT CHMSU FORTUNE TOWNE CAMPUS

SCOPE OF WORKS

1.0 GENERAL REQUIREMENTS

- 1.1 Mobilization & Demobilization
- 1.2 Safety Occupational Hazards
- 1.3 Demolition and Dismantling Works (Portion)
- 1.4 Site Clearing, Cleaning and Hauling

2.0 ARCHITECTURAL WORKS

- 2.1 Supply and Installation of Doors Jamb and Door with complete accessories
 - 2.1.1 Installation of Door Jamb
 - 2.1.2 Installation of Door
- 2.2 Supply and Installation of Glass Partition
 - 2.2.1 Supply and installation of Aluminum fixed glass partition with frosted film tint and Jalousie window transom (see detailed plan)
- 2.3 Painting and Finishing Works
 - 2.3.1 Retouching and painting of affected portion during the installation of Doors and Glass Partition

3.0 CONCRETING AND MASONRY WORKS

- 3.1 Plastering of walls
- 3.2 Concreting topping of damage floor (see location details)

4.0 MISCELLANEOUS WORKS

BILL OF QUANTITIES

- 1.0 GENERAL REQUIREMENTS
 - 1.1 Mobilization & Demobilization 1 lot
 - 1.2 Safety Occupational Hazards 1 lot
 - 1.3 Demolition and Dismantling Works (Portion) 1 lot
 - 1.4 Site cleaning & hauling 1 lot

SUB-TOTAL OF GENERAL REQUIREMENTS

2.0 ARCHITECTURAL WORKS

- 2.1 Supply and Installation of Doors Jamb and Door with complete accessories
 - 2.1.1 Panel Door (2.10 m H x 0.90m W) and door jamb with complete accessories (labor and materials) 1 set
- 2.2 Supply and Installation of Glass Partition
 - 2.2.1 Supply and installation of Aluminum fixed glass partition with frosted film tint and Jalousie window transom (see detailed plan) 1 set
- 2.3 Painting and Finishing Works
 - 2.3.1 Labor and painting materials for retouching of affected portion of walls 1 lot

SUB-TOTAL OF ARCHITECTURAL WORKS

3.0 CONCRETING AND MASONRY WORKS

- 3.1 Cement 4 bag
- 3.2 Mixing sand 1 cu.m

SUB-TOTAL OF CONCRETING AND MASONRY WORKS

4.0 MISCELLANEOUS WORKS

FOR ALL OTHER ITEMS that are not included on listed Bill of Quantities in your Bid but are deemed necessary for the completion of the works and the delivery of the project. 1 lot

SUB-TOTAL OF MISCELLANEOUS WORKS

PROJECT DURATION: 20 CALENDAR DAYS

Note: Attach Certificate of Site Inspection

- A. TOTAL DIRECT COST
- B. CONSUMABLES:
- C. SUPERVISION AND ADMINISTRATION:
- D. TOTAL INDIRECT COST (B+C):
- E. TOTAL COST (A+D)
- F. VAT (12% OF ITEM E):
- GRAND TOTAL OF PROJECT COST:
- *****NOTHING FOLLOWS*****

TOTAL ABC = Php 100,000.00
 PROCUREMENT OF LABOR AND MATERIALS FOR THE INSTALLATION OF GLASS DIVISION FOR CASHIER AND
 ASSESSMENT OFFICES AND A SEPARATE DOOR FOR THE CASHIER'S OFFICE AT CHMSU FORTUNE TOWNE CAMPUS/
 A. SALES

PR# 24-356-0503 05-03-24
MDS 147-101-24-05 05-06-24

Line Items

Item No.	Product/Service Name	Description	Quantity	UOM	Budget (PHP)
1	ONE (1) LOT	Glass Division and Separate Door	1	Lot	100,000.00

Created by Rowena De la Vida Prado

Date Created 07/06/2024

The PhilGEPS team is not responsible for any typographical errors or misinformation presented in the system. PhilGEPS only displays information provided for by its clients, and any queries regarding the postings should be directed to the contact person/s of the concerned party.



Republic of the Philippines
CARLOS HILADO MEMORIAL STATE UNIVERSITY
 Talisay City, Negros Occidental
 Mobile Phone Number: 0939 929 6624
bac.sec@chmsu.edu.ph

REQUEST FOR QUOTATION

Page 1 of 5

Date: JUNE 06, 2024
 Quotation No. 24-264

Please quote your lowest price on the item/s listed below, stating the shortest time of delivery and submit your quotation duly signed by your representative not later than _____ in the return envelope attached herewith.

DR. ANDREW EUSEBIO S.TAN
 BAC Chairman

NOTE:

1. ALL ENTRIES MUST BE TYPEWRITTEN
2. DELIVERY PERIOD WITHIN 20 CALENDAR DAYS
3. WARRANTY SHALL BE FOR A PERIOD OF SIX (6) MONTHS FOR SUPPLIES & MATERIALS, ONE (1) YEAR FOR EQUIPMENT, FROM DATE OF ACCEPTANCE BY THE PROCURING ENTITY
4. PRICE VALIDITY SHALL BE FOR A PERIOD OF _____ CALENDAR DAYS
5. G-EPS REGISTRATION CERTIFICATE SHALL BE ATTACHED UPON SUBMISSION OF THE QUOTATION
6. BIDDERS SHALL SUBMIT ORIGINAL BROCHURES SHOWING CERTIFICATIONS OF THE PRODUCT BEING OFFERED

ITEM NO.	DESCRIPTION OF WORKS	QTY.	UNIT	MATERIAL COST		LABOR COST		TOTAL COST
				Unit Cost	Material Sub-Total Cost	Unit Cost	Labor Sub-Total Cost	
	ONE (1) LOT							
	LABOR AND MATERIALS FOR THE INSTALLATION OF GLASS DIVISION FOR CASHIER AND ASSESSMENT OFFICES AND A SEPARATE DOOR FOR THE CASHIER'S OFFICE AT CHMSU FORTUNE TOWNE CAMPUS							
	SCOPE OF WORKS							
1.0	GENERAL REQUIREMENTS							
1.1	Mobilization & Demobilization							
1.2	Safety Occupational Hazards							
1.3	Demolition and Dismantling Works (Portion)							
1.4	Site Clearing, Cleaning and Hauling							
2.0	ARCHITECTURAL WORKS							
2.1	Supply and Installation of Doors Jamb and Door with complete accessories							
2.1.1	Installation of Door Jamb							
2.1.2	Installation of Door							

Released (BAC) _____ Date _____ By _____
 Returned (Supplier) _____

 Printed Name/Signature

 Tel. No./Cellphone No.

 Date



Republic of the Philippines
CARLOS HILADO MEMORIAL STATE UNIVERSITY
 Talisay City, Negros Occidental
 Mobile Phone Number: 0939 929 6624
bac.sec@chmsu.edu.ph

REQUEST FOR QUOTATION

Page 2 of 5

Date: JUNE 06, 2024
 Quotation No. 24-264

Please quote your lowest price on the item/s listed below, stating the shortest time of delivery and submit your quotation duly signed by your representative not later than _____ in the return envelope attached herewith.

DR. ANDREW EUSEBIO S.TAN
 BAC Chairman

NOTE:

1. ALL ENTRIES MUST BE TYPEWRITTEN
2. DELIVERY PERIOD WITHIN 20 CALENDAR DAYS
3. WARRANTY SHALL BE FOR A PERIOD OF SIX (6) MONTHS FOR SUPPLIES & MATERIALS, ONE (1) YEAR FOR EQUIPMENT, FROM DATE OF ACCEPTANCE BY THE PROCURING ENTITY
4. PRICE VALIDITY SHALL BE FOR A PERIOD OF _____ CALENDAR DAYS
5. G-EPS REGISTRATION CERTIFICATE SHALL BE ATTACHED UPON SUBMISSION OF THE QUOTATION
6. BIDDERS SHALL SUBMIT ORIGINAL BROCHURES SHOWING CERTIFICATIONS OF THE PRODUCT BEING OFFERED

ITEM NO.	DESCRIPTION OF WORKS	QTY.	UNIT	MATERIAL COST		LABOR COST		TOTAL COST
				Unit Cost	Material Sub-Total Cost	Unit Cost	Labor Sub-Total Cost	
2.2	Supply and Installation of Glass Partition							
2.2.1	Supply and installation of Aluminum fixed glass partition with frosted film tint and Jalousie window transom (see detailed plan)							
2.3	Painting and Finishing Works							
2.3.1	Retouching and painting of affected portion during the installation of Doors and Glass Partition							
3.0	CONCRETING AND MASONRY WORKS							
3.1	Plastering of walls							
3.2	Concreting topping of damage floor (see location details)							
4.0	MISCELLANEOUS WORKS							
BILL OF QUANTITIES								
1.0	GENERAL REQUIREMENTS							
1.1	Mobilization & Demobilization	1	lot					
1.2	Safety Occupational Hazards	1	lot					

Released (BAC) _____ Date _____
 Returned (Supplier) _____ By _____

 Printed Name/Signature

 Tel. No./Cellphone No.

 Date



Republic of the Philippines
CARLOS HILADO MEMORIAL STATE UNIVERSITY
Talisay City, Negros Occidental
Mobile Phone Number: 0939 929 6624
bac.sec@chmsu.edu.ph

REQUEST FOR QUOTATION

Page 3 of 5

Date: JUNE 06, 2024
Quotation No. 24-264

Please quote your lowest price on the item/s listed below, stating the shortest time of delivery and submit your quotation duly signed by your representative not later than _____ in the return envelope attached herewith.

DR. ANDREW EUSEBIO S.TAN
BAC Chairman

NOTE:

1. ALL ENTRIES MUST BE TYPEWRITTEN
2. DELIVERY PERIOD WITHIN 20 CALENDAR DAYS
3. WARRANTY SHALL BE FOR A PERIOD OF SIX (6) MONTHS FOR SUPPLIES & MATERIALS, ONE (1) YEAR FOR EQUIPMENT, FROM DATE OF ACCEPTANCE BY THE PROCURING ENTITY
4. PRICE VALIDITY SHALL BE FOR A PERIOD OF _____ CALENDAR DAYS
5. G-EPS REGISTRATION CERTIFICATE SHALL BE ATTACHED UPON SUBMISSION OF THE QUOTATION
6. BIDDERS SHALL SUBMIT ORIGINAL BROCHURES SHOWING CERTIFICATIONS OF THE PRODUCT BEING OFFERED

ITEM NO.	DESCRIPTION OF WORKS	QTY.	UNIT	MATERIAL COST		LABOR COST		TOTAL COST
				Unit Cost	Material Sub-Total Cost	Unit Cost	Labor Sub-Total Cost	
1.3	Demolition and Dismantling Works (Portion)	1	lot					
1.4	Site cleaning & hauling	1	lot					
	SUB-TOTAL OF GENERAL REQUIREMENTS							
2.0	ARCHITECTURAL WORKS							
2.1	Supply and Installation of Doors Jamb and Door with complete accessories							
2.1.1	Panel Door (2.10 m H x 0. 90m W) and door jamb with complete accessories (labor and materials)	1	set					
2.2	Supply and Installation of Glass Partition							
2.2.1	Supply and installation of Aluminum fixed glass partition with frosted film tint and Jalousie window transom (see detailed plan)	1	set					
2.3	Painting and Finishing Works							
2.3.1	Labor and painting materials for retouching of affected portion of walls	1	lot					

Date

By

Released (BAC) _____
Returned (Supplier) _____

Printed Name/Signature

Tel. No./Cellphone No.

Date



Republic of the Philippines
CARLOS HILADO MEMORIAL STATE UNIVERSITY
 Talisay City, Negros Occidental
 Mobile Phone Number: 0939 929 6624
bac.sec@chmsu.edu.ph

REQUEST FOR QUOTATION

Page 4 of 5

Date: JUNE 06, 2024
 Quotation No. 24-264

Please quote your lowest price on the item/s listed below, stating the shortest time of delivery and submit your quotation duly signed by your representative not later than _____ in the return envelope attached herewith.

DR. ANDREW EUSEBIO S.TAN
 BAC Chairman

NOTE:

1. ALL ENTRIES MUST BE TYPEWRITTEN
2. DELIVERY PERIOD WITHIN 20 CALENDAR DAYS
3. WARRANTY SHALL BE FOR A PERIOD OF SIX (6) MONTHS FOR SUPPLIES & MATERIALS, ONE (1) YEAR FOR EQUIPMENT, FROM DATE OF ACCEPTANCE BY THE PROCURING ENTITY
4. PRICE VALIDITY SHALL BE FOR A PERIOD OF _____ CALENDAR DAYS
5. G-EPS REGISTRATION CERTIFICATE SHALL BE ATTACHED UPON SUBMISSION OF THE QUOTATION
6. BIDDERS SHALL SUBMIT ORIGINAL BROCHURES SHOWING CERTIFICATIONS OF THE PRODUCT BEING OFFERED

ITEM NO.	DESCRIPTION OF WORKS	QTY.	UNIT	MATERIAL COST		LABOR COST		TOTAL COST
				Unit Cost	Material Sub-Total Cost	Unit Cost	Labor Sub-Total Cost	
	SUB-TOTAL OF ARCHITECTURAL WORKS							
3.0	CONCRETING AND MASONRY WORKS							
3.1	Cement	4	bag					
3.2	Mixing sand	1	cu.m					
	SUB-TOTAL OF CONCRETING AND MASONRY WORKS							
4.0	MISCELLANEOUS WORKS							
	FOR ALL OTHER ITEMS that are not included on listed Bill of Quantities in your Bid but are deemed necessary for the completion of the works and the delivery of the project.	1	lot					
	SUB-TOTAL OF MISCELLANEOUS WORKS							
	PROJECT DURATION: 20 CALENDAR DAYS							

Released (BAC) _____ Date _____ By _____
 Returned (Supplier) _____

Printed Name/Signature

Tel. No./Cellphone No.

Date



Republic of the Philippines
CARLOS HILADO MEMORIAL STATE UNIVERSITY
 Talisay City, Negros Occidental
 Mobile Phone Number: 0939 929 6624
bac.sec@chmsu.edu.ph

REQUEST FOR QUOTATION

Page 5 of 5

Date: JUNE 06, 2024
 Quotation No. 24-264

Please quote your lowest price on the item/s listed below, stating the shortest time of delivery and submit your quotation duly signed by your representative not later than _____ in the return envelope attached herewith.

DR. ANDREW EUSEBIO S.TAN
 BAC Chairman

NOTE:

1. ALL ENTRIES MUST BE TYPEWRITTEN
2. DELIVERY PERIOD WITHIN 20 CALENDAR DAYS
3. WARRANTY SHALL BE FOR A PERIOD OF SIX (6) MONTHS FOR SUPPLIES & MATERIALS, ONE (1) YEAR FOR EQUIPMENT, FROM DATE OF ACCEPTANCE BY THE PROCURING ENTITY
4. PRICE VALIDITY SHALL BE FOR A PERIOD OF _____ CALENDAR DAYS
5. G-EPS REGISTRATION CERTIFICATE SHALL BE ATTACHED UPON SUBMISSION OF THE QUOTATION
6. BIDDERS SHALL SUBMIT ORIGINAL BROCHURES SHOWING CERTIFICATIONS OF THE PRODUCT BEING OFFERED

ITEM NO.	DESCRIPTION OF WORKS	QTY.	UNIT	MATERIAL COST		LABOR COST		TOTAL COST
				Unit Cost	Material Sub-Total Cost	Unit Cost	Labor Sub-Total Cost	
	Note: Attach Certificate of Site Inspection							
	A. TOTAL DIRECT COST							
	B. CONSUMABLES:							
	C. SUPERVISION AND ADMINISTRATION:							
	D. TOTAL INDIRECT COST (B+C):							
	E. TOTAL COST (A+D)							
	F. VAT (12% OF ITEM E):							
	GRAND TOTAL OF PROJECT COST:							
	*****NOTHING FOLLOWS*****							
	TOTAL ABC = Php 100,000.00							
	PROCUREMENT OF LABOR AND MATERIALS FOR THE INSTALLATION OF GLASS DIVISION FOR CASHIER AND ASSESSMENT OFFICES AND A SEPARATE DOOR FOR THE CASHIER'S OFFICE AT CHMSU FORTUNE TOWNE CAMPUS/ A. SALES							
	PR# 24-356-0503 05-03-24							
	MDS 147-101-24-05 05-06-24							

Date _____ By _____

Released (BAC) _____

Returned (Supplier) _____

Printed Name/Signature _____

Tel. No./Cellphone No. _____

Date _____



Republic of the Philippines
**CARLOS HILADO MEMORIAL
 STATE UNIVERSITY**

PROJECT TITLE:
**INSTALLATION OF GLASS DIVISION FOR CASHIER AND ASSESSMENT
 OFFICES AND A SEPARATE DOOR FOR THE CASHIER'S OFFICE**

PROJECT LOCATION: FORTUNE TOWNE CAMPUS

PREPARED BY:
MA. PRESENDO L. MANZAN
 University Designer

ALFONSO D. SALES JR., Ph.D.
 PDDM Coordinator

RECOMMENDING APPROVAL

[Signature]
RUVY M. TUBLE, Ph.D.
 Campus Director

[Signature]
ENR. JUN-JUN MARQUEZ
 PDDM Director

[Signature]
MRS ROSALINDA S. TUVILLA
 Vice-President for Administration and Finance

[Signature]
NORBERTO P. MANGULABUAN, Ph.D.
 SUC President III

APPROVED BY:

SHEET NO.

A
1

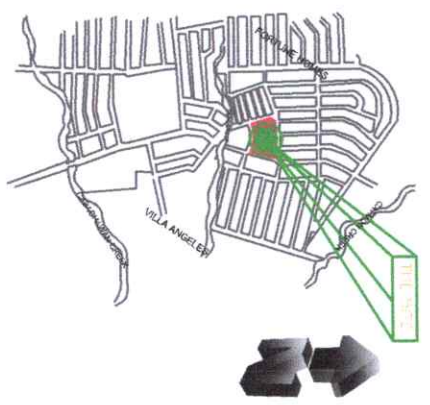

1
A1

SCALE

VICINITY MAP

NDTS



2
A1

SCALE

SITE DEV'T PLAN

NDTS

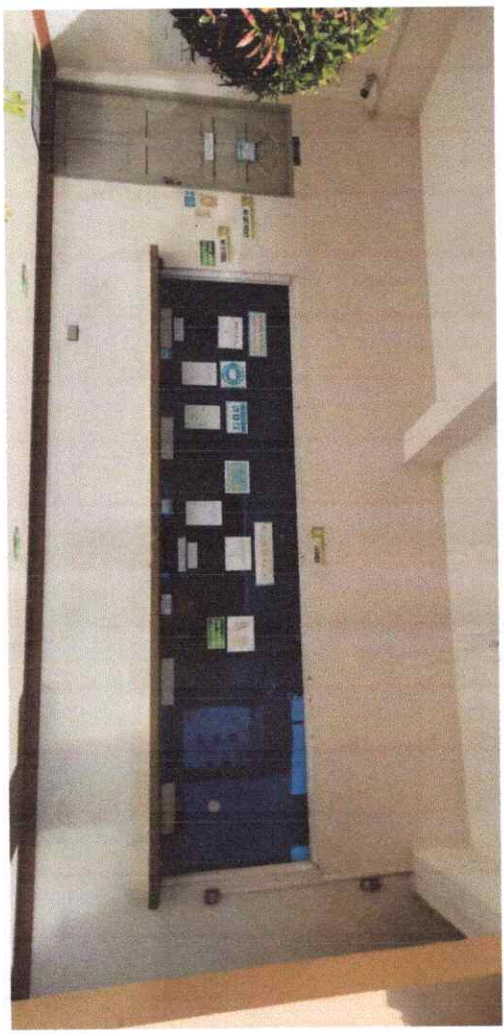

3
A1

SCALE

PERSPECTIVE

NDTS

4/14/2014



Republic of the Philippines
CARLOS HILADO MEMORIAL STATE UNIVERSITY

PROJECT TITLE:

INSTALLATION OF GLASS DIVISION FOR CASHIER AND ASSESSMENT OFFICES AND A SEPARATE DOOR FOR THE CASHIER'S OFFICE

PROJECT LOCATION: FORTUNE TOWNE CAMPUS

PREPARED BY

M.A. PRESERENDE MANZAN
 University Designer

RECOMMENDING APPROVAL

[Signature]
RUVY M. TUBLE, Ph.D.
 Campus Director

APPROVED BY:

[Signature]
NORBERTO P. MANANGALABANAN, Ph.D.
 SUC President III

A
2

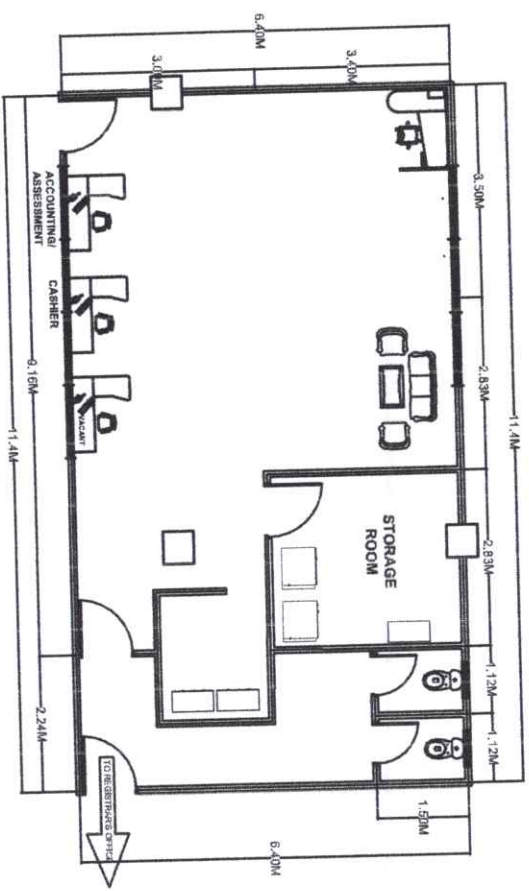

EXISTING PLAN

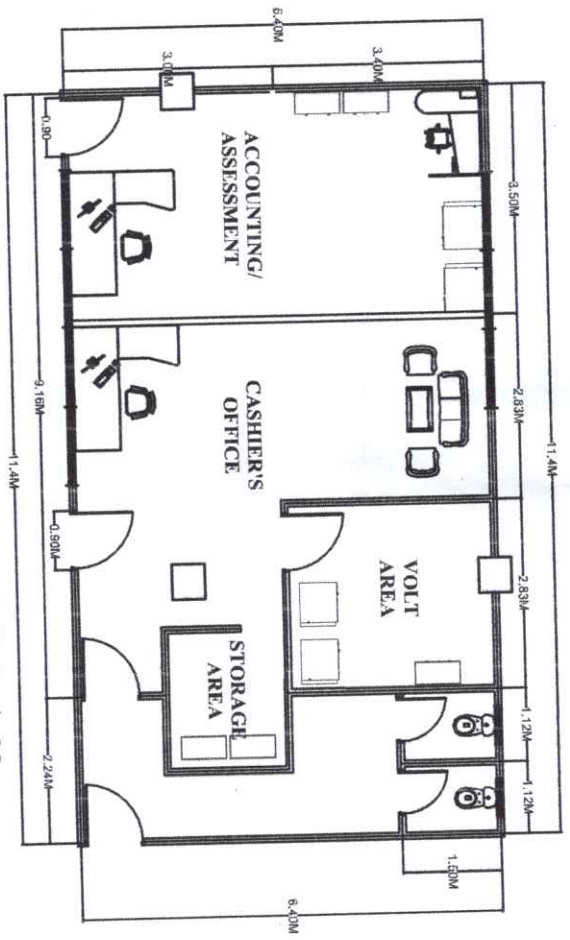

PROPOSED PLAN

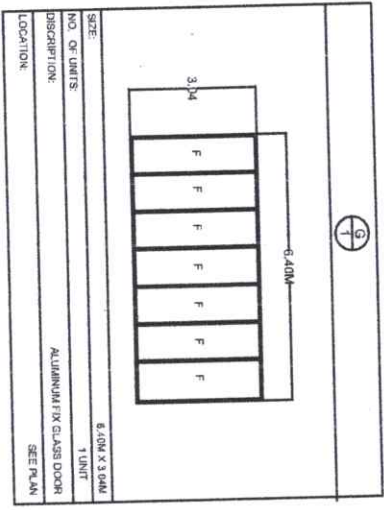
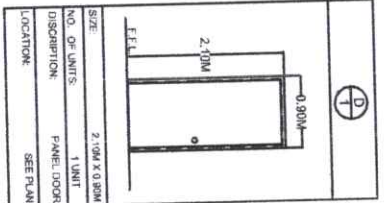

SCHEDULE OF DOOR AND GLASS PARTITION



Republic of the Philippines CARLOS HILADO MEMORIAL STATE UNIVERSITY		PREPARED BY: MA. PRESENCE E. ANZAN University Director	RECOMMENDING APPROVAL RUYVY H. KUBLE, Ph.D. Campus Director	APPROVED BY: MRS. ROSALINDA S. TUVALLA Vice President for Administration and Finance	SHEET NO. A
CARLOS HILADO MEMORIAL STATE UNIVERSITY		PROJECT TITLE: INSTALLATION OF GLASS PARTITION FOR CASHIER AND ASSESSMENT OFFICES AND A SEPARATE DOOR FOR THE CASHIER'S OFFICE	PPDm Director ENGR. JUN-JUN J. MARQUEZ	NORBERTO F. MANCULABAN, Ph.D. SUC President, III	3
PROJECT LOCATION: FORTUNE TOWNE CAMPUS					

GLASS PARTITION DETAIL

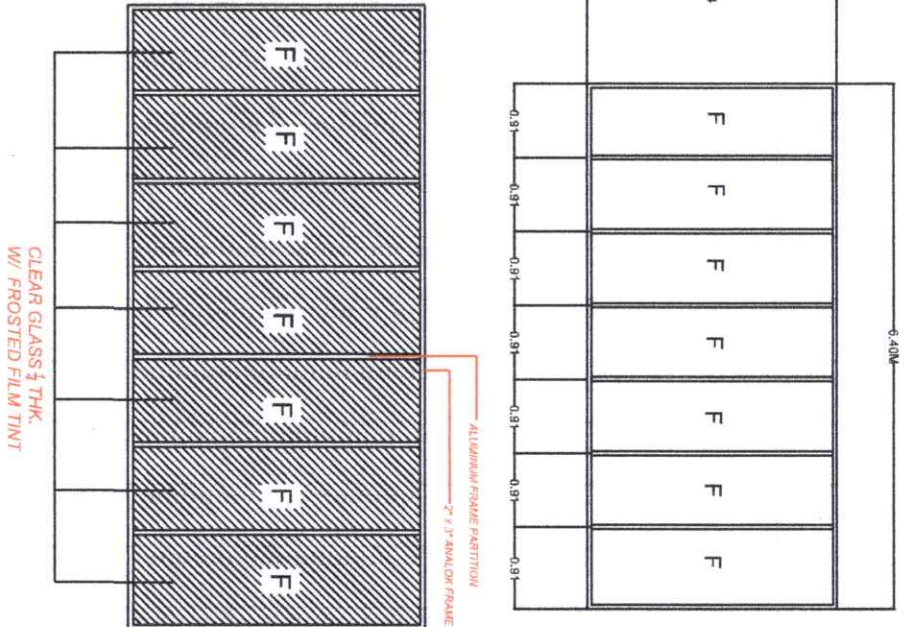

GLASS PARTITION PERSPECTIVE

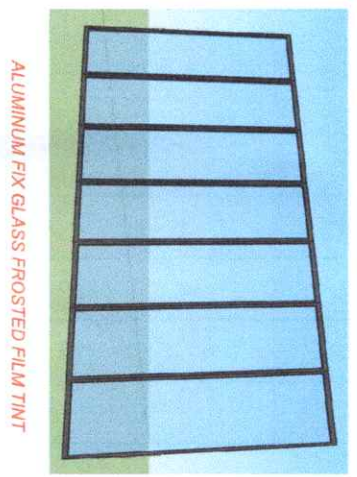



Republic of the Philippines
**CARLOS HILADO MEMORIAL
 STATE UNIVERSITY**

PROJECT TITLE:
**INSTALLATION OF GLASS DIVISION FOR CASINER AND ASSESSMENT
 OFFICES AND A SEPARATE DOOR FOR THE CASINER'S OFFICE**

PROJECT LOCATION: FORTUNE TOWNE CAMPUS

PREPARED BY:
 MA. PRESERINDE V. MANZAN
 University Designer

ALEJANDRO D. SALES JR., Ph.D.
 PPDm Coordinator

RECOMMENDING APPROVAL

M. TUBLE, Ph.D.
 Campus Director

ENRIQUE JUN J. VESQUEZ
 PPDm Director

MRS. ROSALINDA S. TAVILLA
 Vice President for Administration
 and Finance

NORBERTO P. MANGALABANAN, Ph.D.
 SUN President III

APPROVED BY:

SHEET NO.
A
4

1 NEW INSTALL DOOR DETAIL

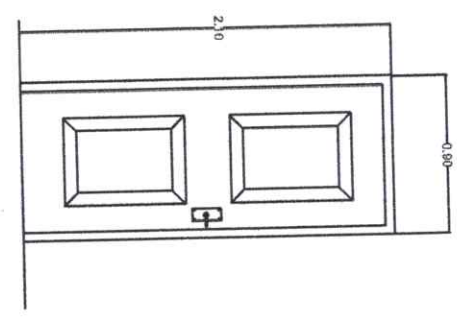
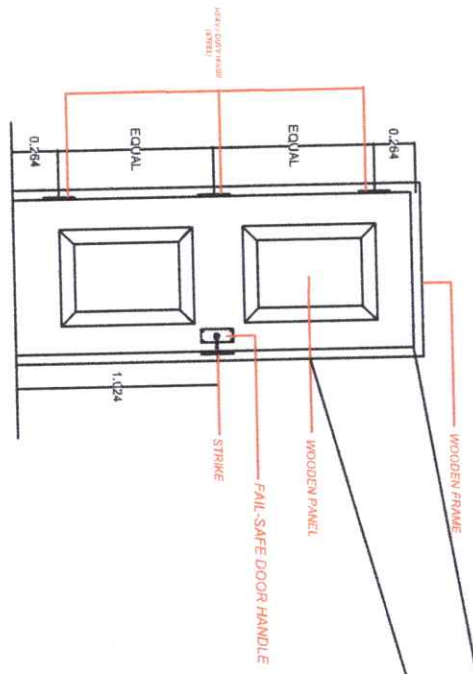

2 NEW INSTALL DOOR PERSPECTIVE

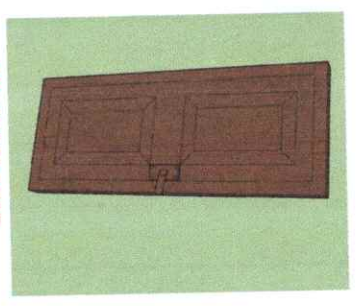
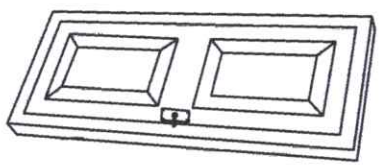

TWO PANEL DOOR

3 NEW INSTALL DOOR ELEVATION

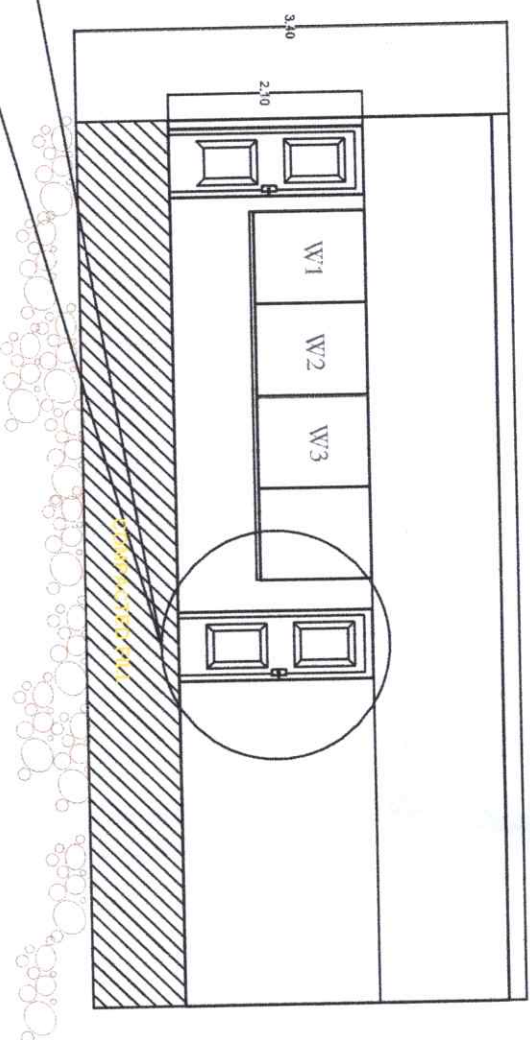

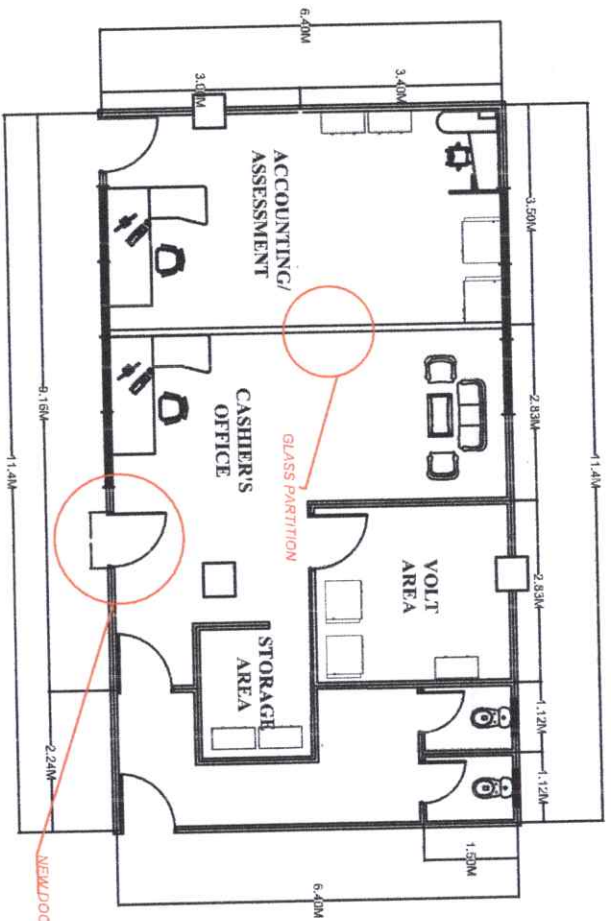

1 LOCATION OF GLASS PARTITION AND NEW DOOR
A/5 SCALE



2 FLOOR TOPPING DETAIL
A/5 SCALE

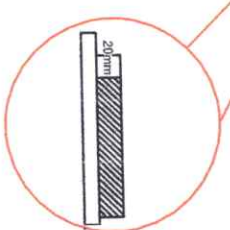

Republic of the Philippines CARLOS HILADO MEMORIAL STATE UNIVERSITY		PREPARED BY: MA. PRESENDAQUE V. MANZAN University Draftsman		RECOMMENDING APPROVAL: RUY M. T. BALLE, Ph.D. Campus Director	
PROJECT TITLE: INSTALLATION OF GLASS DIVISION FOR CASHIERS AND ASSESSMENT OFFICES AND A SEPARATE BOOTH FOR THE CASHIERS'S OFFICE		 ATTORNEY D. SALES JR., Ph.D. PPDm Coordinator		 JUN-JUN MARQUEZ PPDm Director	
PROJECT LOCATION: FORTUNE TOWNE CAMPUS		 MRS. ROSALINDA S. TUNILLA Vice President for Administration and Finance		 NORBERTO P. MANGUABANAN, Ph.D. SUC President III	
				SHEET NO.	
				A	
				5	